

ALMOST READY TO FLY MODEL

J3-PIPER CUB L4-GRASSHOPPER



28B- Battery compartment as seen from bottom of fuselage

28C- Battery installed with security velcro

28D- Battery hatch installed with Fuse in place

Once the CG is correct, the battery should be secured in position with Velcro (supplied) or lightweight foam so that the battery cannot move.

After installing your battery and securing it into place, re-install the battery hatch as shown in 28C.

When you are ready to power up your motor, **MAKE SURE YOUR TRANSMITTER IS TURNED ON WITH THE THROTTLE REDUCED TO ZERO & STAY CLEAR OF THE PROP BEFORE INSTALLING THE FUSE.**

After installing the fuse, **STAY CLEAR OF THE PROP**

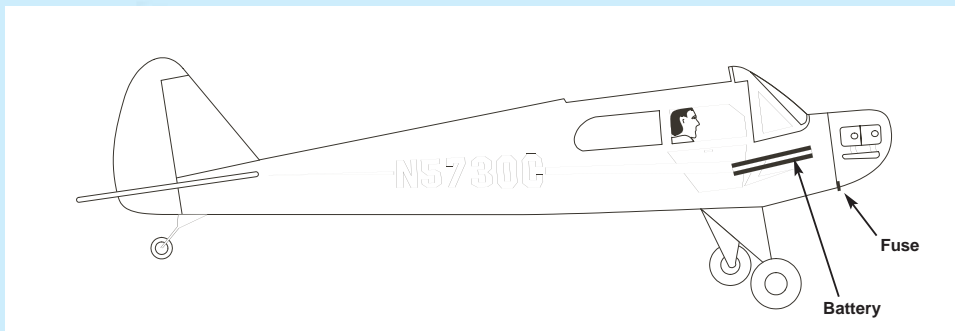

Notes

ASSEMBLY & OPERATIONS MANUAL

Please review this manual thoroughly before assembling or operating this model.

Proceeding with assembly and use of this product indicates Agreement With & Acceptance of the following Liability Disclaimer.

Model airplanes, model engines, model engine fuel, propellers and related accessories, tools and equipment can be hazardous if improperly used. Be cautious and follow all safety recommendations when using your VMAR model airplane. Keep hands, tools, clothing and all foreign objects well clear of engines when they are operating. Take particular care to safeguard and protect your eyes and fingers and the eyes and fingers of other persons who may be nearby. Use only a good quality propeller that has no cracks or flaws. Stay clear of the propeller and stay clear of the plane of rotation defined by the propeller. The Manufacturer, Distributor, Retailer and/or other

suppliers of this product expressly disclaim any warranties or representations, either expressed or implied, including but not limited to implied warranties of fitness for the purposes of achieving and sustaining remotely controlled flight. In no event will the Manufacturer, Distributor, Retailer and/or other suppliers of this product have any obligation arising from contract or tort, or for loss of revenue or profit, or for indirect, special, incidental, consequential or other damages arising from the use of this product. In purchasing and/or using this product, the user accepts all responsibility for its use and accepts all liability associated with such use.

CAUTION

A Remote Control Model Aircraft is not a toy. It is a flying model that functions much like a full size airplane. If you do not assemble and operate this product properly you can cause injury to yourself and others and damage property. DO NOT FLY this model if you are not qualified.

You are entirely responsible for the mechanical, aeronautical and electrical integrity of this model and it's structure, control surfaces, hinges, linkages, covering, engine, radio, wiring, battery and all other components. Check all components before and after each flight.

Don't fly until it's right!



FOR SUPPORT SERVICES, PARTS & INFORMATION ABOUT THESE & OTHER VMAR PRODUCTS PLEASE VISIT US AT... www.richmondrc.com

VMAR, POLYCOTE and VMAX are Trademarks of VMAR Manufacturing Inc. and appointed VMAR agents worldwide. Copyright VMAR Manufacturing Inc - #VMA-C210XIB - 20060510



POLYCOTE™ ECS
ENHANCED COVERING SYSTEM



The Graphics and Detailing are inside the POLYCOTE ECS!

STAGE 1 WING ASSEMBLY - JOINING THE WING HALVES

Parts needed

- Roll of wing joiner tape
- Right and left wing panels
- Wing joiner (also called dihedral brace)

Step 1.1 Locate the wing joiner (also called Dihedral brace). Using a ruler, determine the center of the wing joiner and mark it with a pencil as illustrated in 1B.

Step 1.2 Trial fit the wing joiner into the wing panels. It should insert smoothly up to the center line as illustrated in



1A- Left and right wing panels

Step 1.3 Apply plenty of 30 minute Epoxy to one end of the wing joiner using a stir stick or epoxy brush as illustrated in 1D. Carefully insert the epoxy coated half of the wing joiner into one wing panel as illustrated in 1E.

See 1F and use a cloth or tissue to wipe away any excess epoxy that squeezes out of the joint. Repeat this process



1C- Trial fit the wing joiner

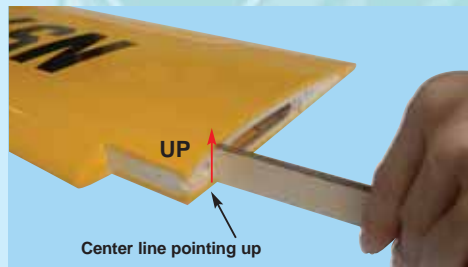

1E- Carefully insert the joiner all the way to the center line

Tools and Adhesives needed

- 30 minute epoxy
- Epoxy brush or stir sticks
- Disposable mixing dish for the epoxy
- Sandpaper (Coarse 240 grit recommended)
- Low tack masking tape
- Pencil, knife, ruler
- Paper towels

1C. Now slide the other wing panel onto the wing joiner until the wing panels meet. If the fit is overly tight, sand the wing joiner slightly and try again. Mark the joiner to indicate which way is UP as illustrated in 1B.

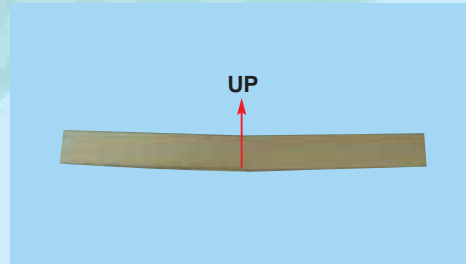

1B- Preparation of wing joiner

several times to ensure the wing joiner and cavity are well coated with 30 minute epoxy. When the wing joiner & cavity are well coated with 30 minute epoxy, insert the joiner to the center line, wipe away any excess epoxy and let dry. (Note: Do not use 5 minute epoxy or CA to join the wings).



1D- Apply plenty of 30 minute epoxy to the wing joiner



1F - Wipe off the excess epoxy then allow to cure

STAGE 27 INSTALLING THE DUMMY PILOT

This model comes with a dummy pilot. To remove and/or install the dummy pilot please review the illustrations and follow these steps.

Step 27.1 To remove the dummy pilot unscrew the 2 screws (see picture 27C)

Step 27.2 The dummy pilot is installed using two 2x10 [mm] sheet metal screws. See 27C and 27D.



27A- Dummy pilot



27B- Pre-installed dummy pilot mounting rail



27C - Position the dummy pilot onto the rails.

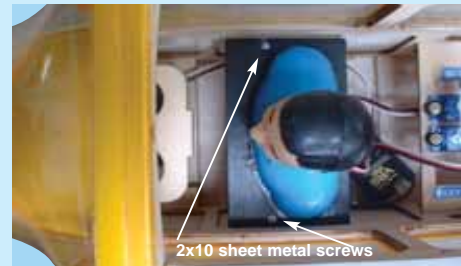

27D - Position the dummy pilot onto the rails and secure into place with two 2x10 [mm] screws.



27E- Dummy pilot after installation

STAGE 28 BATTERY LOCATION

The battery location is behind the firewall. To install the battery, you must remove the battery hatch first then connect the battery to your ESC.

Battery packs vary widely in size, shape and type. We recommend using a Lithium Polymer (LIPO) battery.

The battery can be moved fore or aft to adjust the CG to the correct location. See 28B

Once the CG is correct, the battery should be secured in position with Velcro (supplied) or lightweight foam so that the battery cannot move.

DO NOT FLY WITH A LOOSE BATTERY. If the battery moves it will shift the CG location and/or possibly unplug itself causing loss of control.

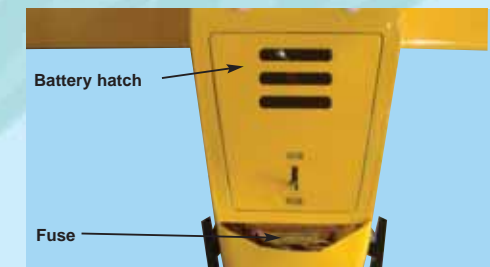

28A- Battery hatch shown in position

STAGE 26 INSTALLING THE WING STRUTS

Wing struts are very important. They must be correctly installed and remain securely attached at all times during flight. The wing will fail if flown without the struts.

To install the wing struts you need the struts themselves & the four 2x10 [mm] screws supplied. Review the general configuration of the struts shown in 26G.

Step 26.1 Locate the strut attachment point on the underside of each wing near the aileron servo. The locations have been pre-marked at the factory. See 26A & 26B

Step 26.2 Locate the strut attachment points on the fuselage near the main gear. The locations have been pre-marked at the factory. See 26C and 26D

Step 26.3 Mount the wing to fuselage.

Step 26.4 Attach the struts to the left and right wing so that the thicker edge of the strut faces forward. See 26E

Step 26.5 Attach the struts to the fuselage. See 26F

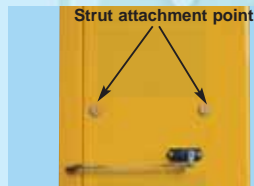

26A- Strut attachment point on the underside of the right wing



26B- Strut attachment point on the underside of the left wing

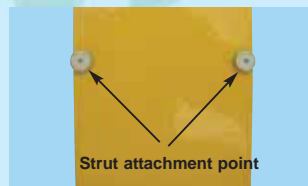

26C- Strut attachment point on the left side of the fuselage

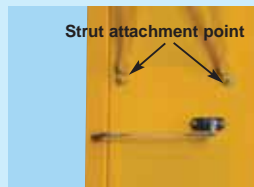

26D- Strut attached to the right wing panel



26E- Strut attached to the left wing panel



26F - Left & right struts attached to model.



26G- Left & right struts attached to model

STAGE 2 WING ASSEMBLY - JOINING THE WING HALVES (Cont.)

Step 2.1 When the epoxy has cured in Stage 1, trial fit the second wing panel onto the wing joiner first to ensure that the two panels fit without an excessive gap.

Step 2.2 Now apply plenty of epoxy to the wing joiner and wing root ribs of both wing panels. Use only 30 minute epoxy to ensure a strong bond and give yourself plenty of working time. As described in the Step 1.3, repeatedly

apply epoxy and insert into the wing joiner cavity, the epoxy should ooze from the joint and the excess should be cleaned off with a rag or tissue before it cures.

Step 2.3 Use low tack masking tape to align the wing surfaces and hold the two panels together until the epoxy cures.

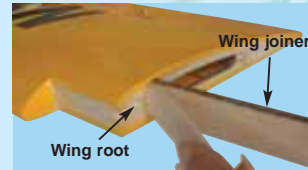

2A- Apply plenty of 30 minute epoxy glue to all surfaces



2B- Align the two wing panels and slowly close the gap until the wing root ends are firmly in contact with each other



2C- Use low tack masking tape to hold tightly together

Step 2.4 Once the epoxy has cured completely (allow several hours at least), the tape can be carefully removed from the wing panels. Peel the tape back on itself... do not pull upright away from the wing. To seal and finish the joint in the wings, a roll of wing joiner tape has been

supplied. Starting on the bottom side of the wing, stick the tape centrally over the joint ensuring that it is pressed down firmly as you work around the wing. Wrap the tape all the way around the wing joint in one piece, starting and finishing on the bottom.



2D- Apply tape over the joint starting here on the bottom as shown



2E- Continue applying the tape over the top of the wing, pressing down firmly as you go



2F- Continue back around to the bottom of the wing & overlap the tape where you started. Trim off excess tape

STAGE 3 INSTALLING THE AILERON SERVO INTO THE WING

To install the aileron servos into the wing you will need the following items:

- 2 micro servos (with mounting screws control arms and grommets)
- Two aileron control rod assemblies with a clevis screwed onto both ends
- Low tack masking tape
- 2 aileron control horn assemblies
- 2 aileron extension cables 12 in (30 cm)

Step 3.1 Turn the wing upside down.

Step 3.2 Trial fit the aileron servo into the servo mounting cavity. You may have to modify the cavity slightly to provide clearance for the servo and servo wires.

Step 3.3 Use a hobby knife to modify the cavity as required. Most servos have their output shaft closer to one end than the other. Mount the servo so that the output shaft is closer to the leading edge of the wing.

Step 3.4 Securely attach an aileron extension cable to the servo. Thread the cable through the wing tube to the center of the wing. Screw the servo into place with the screws and grommets supplied. It is important to install the grommets and screws correctly. See the manual that came with your radio for instructions about your particular servo grommets. (Note that in some type servo installation without the grommets)

Step 3.5 Fasten the screws down according to the servo manufacturers recommended tightness.

Step 3.6 Repeat step 3.2 to 3.5 for the other wing panel.



3A- Prepare the servos by fitting the rubber grommets & ferrules supplied with your servos



3B- Aileron servo location

STAGE 4 INSTALLING THE AILERON CONTROL SYSTEM

Step 4.1 Consult your radio instruction manual and center the aileron servos using either a Y connector or a computer radio that accommodates the use of two aileron servos.

Turn on the transmitter and then the receiver. Center the aileron trim lever on the transmitter. Remove the servo arm mounting screws and servo arms.

Step 4.2 Mount the servo arms back on the servos so that the servo arms are parallel with the back edge of the wing. Screw the arms into place using the servo arm mounting screws supplied with the servos.

Step 4.3 Locate the two aileron control rods in the hardware bag (see 4A). Ensure the clevises are screwed well onto the threaded portion of the rod. Rotate and tug aggressively on the clevises and ensure that they are not loose on the rods.

Step 4.4 Tape the ailerons into their neutral position so that they are even with the trailing edge of the wing and not pointing either up or down.

Step 4.5 Install the aileron control horns as illustrated in 4B and ensure they align with the servo arms. use 30 minute epoxy .

Step 4.6 Connect the aileron servo control rods between the aileron control horns and the aileron servo arms as shown in 4C.

Step 4.7 Carefully remove the masking tape holding the ailerons.

Step 4.8 Turn on your radio and activate the ailerons, using the aileron stick and ensure that a smooth full motion can be achieved.

Step 4.9 With the wing top side up and viewed from the back, ensure that moving the transmitter aileron stick to the left raises the left aileron and lowers the right aileron. Movement of the stick to the left will roll the aircraft to the left. (Counterclockwise roll of the wing when viewed from the back).

Step 4.10 With the wing top side up and viewed from the back, ensure that moving the transmitter aileron stick to the right raises the right aileron and lowers the left aileron. Movement of the stick to the right will roll the aircraft to the right. (Clockwise roll of the wing when viewed from the back).

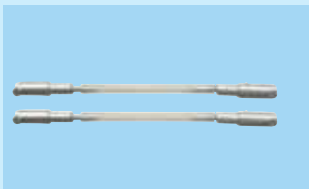

4A- Aileron control rod assembly



4B- Aileron control horn after installation using 30 minute epoxy



4C- Connect the aileron control rod between the servo arm and the control horn

STAGE 5 FITTING THE HORIZONTAL AND VERTICAL STABILIZERS

To install the stabilizers into the fuselage you will need.

- Fuselage
- Vertical stabilizer with pre-installed rudder
- Horizontal stabilizer with pre-installed elevator
- 30 minute epoxy

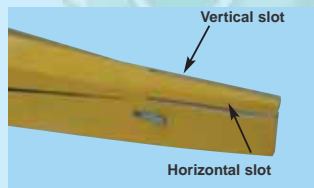

5A- The fuselage slots for the vertical & horizontal stabilizers



5B- Horizontal stabilizer with pre-installed elevator



5C- Vertical stabilizer with pre-installed rudder

STAGE 23 CONFIRM RADIO OPERATION

Carefully review how your Electronic Speed Control (ESC) works. Most ESC's will not power up the motor until the throttle has been reduced to zero. Avoid the prop in case the motor suddenly starts to turn.

Step 23.1 Consult your radio manual for instructions about testing and operating your radio system.

Step 23.2 Pay particular attention to charging your batter-

ies and range testing your system before and after each flight.

Step 23.3 Check that all controls are working correctly before and after each flight.

FOR ELECTRIC POWER, YOU WILL NEED TO INSTALL THE FUSE AND YOUR BATTERY TO TEST YOUR ESC & MOTOR OPERATION

STAGE 24 BALANCING THE AIRCRAFT

Step 24.1 The CG for your J3 PIPER CUB is located at 2" to 2-1/8" (50 - 55 mm) back from the leading edge of the wing when the wing has been attached to the fuselage as per illustration 25A.

Step 24.2 For the initial flight, the CG should be located at 2" (50mm) back from the leading edge of the wing when the wing has been attached to the fuselage.

Step 24.3 The CG is measured with the motor, battery and all other components installed.

Step 24.4 Set up the CG as it will be when you fly it.

Step 24.5 It is very important to have the CG correct. Flying your model with the CG too far back will likely lead to loss

of control and a crash. If you discover that after you have assembled your model and installed your radio, motor and battery that the CG of your model is incorrect you must bring the CG to the correct location by doing the following BEFORE FLYING :

- Move the battery pack fore or aft
- Do not add weight to correct the CG. Move components & especially your battery pack rather than add weight. Only add weight as a measure of last resort.

STAGE 25 CONFIRM MECHANICAL INTEGRITY

Step 25.1 Once you have confirmed that the CG is correct, you should do a thorough review of the entire model before your first flight. Check everything twice! Every hook up, every coupling, everything! Do it twice!!

Step 25.2 Before your first flight, have an experienced flyer review your work. Do not fly your model until it has been checked out by a third party who knows how to fly and how to set up a model aircraft. Do not fly alone. Seek experienced help.

Step 25.3 Once you have completed your first flight, get in the habit of checking your model over before and after each flight! Don't fly if you find something that is not right!

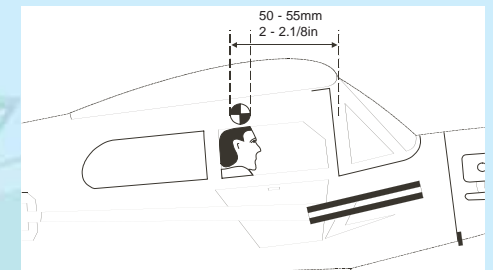

25A- CG location

CONTROL SURFACE THROW SPECIFICATIONS:

The throws are measured at the widest part of the control surface. Adjust the position of the pushrods at the control and/or servo horns to control the amount of throw. You may

also use ATV's if your radio has them but the mechanical linkages should still be set so that the ATV's are near 100% for best servo resolution.

	Low rate		High rate
ELEVATOR	1/6" (4mm) up		1/4" (6 mm) up
	1/6" (4mm) down		1/4" (6 mm) down
AILERON	1/6" (4 mm) up		1/4" (6 mm) up
	1/6" (4 mm) down		1/4" (6 mm) down
RUDDER	1/3" (8 mm) right		2/5" (10 mm) right
	1/3" (8 mm) left		2/5" (10 mm) left

STAGE 20 FINAL RC SET-UP

Before starting the final set-up of the model, switch on the radio and ensure that all trims are in their neutral positions. Check that the ailerons, elevator and rudder are centered. If any adjustments are needed, do these by uncoupling the relevant clevis and turning it clockwise to shorten the linkage or counter-clockwise to lengthen it. Only when each control surface has been centered mechanically in this way should you begin adjusting the surface movement (or throw)

Now confirm that the control surfaces are moving in the correct direction. Use the servo reversing switches on your transmitter to reverse the direction of a servo if necessary. The most popular transmitter mode (with the throttle on the left, with ailerons and elevator on the right) is shown here.

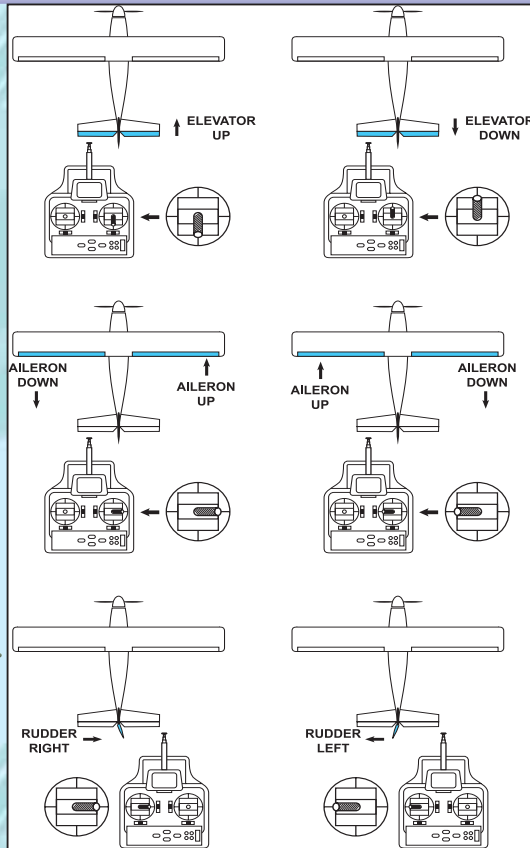

STAGE 21 INSTALLING THE RECEIVER BATTERY (Glow Engine Only)

We have assumed throughout most of these instructions that your J3 Piper cub is being powered by an electric motor and Electronic Speed Control with BEC. Stage 21 applies only if you are using glow power.

Step 21.1 Consult your radio manual for instructions about hooking up your receiver battery, receiver and switch harness.

Step 21.2 Wrap the battery pack securely in foam suitable for RC equipment and wrap the foam insulated pack in a plastic bag or cling wrap. Position the battery pack under the fuel tank or nearby.

Step 21.3 Thread the battery pack connector back through from beneath the fuel tank to the radio compartment by passing the battery connector through an opening beside or beneath the fuel tank.

Step 21.4 Connect the battery connector to your radio system according to the radio manual.

PLEASE NOTE THAT A FUEL TANK IS NOT SUPPLIED WITH THIS MODEL.

STAGE 22 INSTALLING THE RECEIVER

Step 22.1 Consult your radio manual for instructions about hooking up your receiver.

Step 22.2 Plan where you are going to put the receiver with consideration for routing the antenna safely.

Step 22.3 Wrap the receiver securely in foam suitable for RC equipment and wrap the foam insulated receiver in a

plastic bag or cling wrap.

Step 22.4 Generally in the absence of specific instructions from the radio manufacturer, it is recommended that the receiver should be placed where it is least likely to have impact during a crash. Keep the battery pack and other heavy loose items ahead of the receiver.

STAGE 6 ALIGNMENT OF HORIZONTAL STABILIZER

Check the fit of the horizontal stabilizer in its slot. Make sure the horizontal stabilizer is square and centered to the fuselage by taking measurements as shown in pictures 6A, 6B and 6C.

Do not glue anything yet.

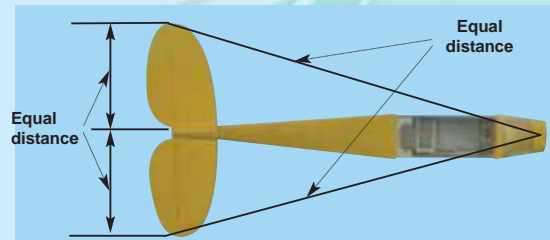

6B- Alignment of horizontal stabilizer top view

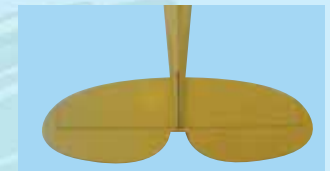

6A- Trial fit the horizontal stabilizer in its slot

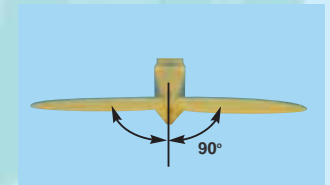

6C- Alignment back view

STAGE 7 INSTALLING THE HORIZONTAL STABILIZER

Step 7.1 With the horizontal stabilizer-aligned correctly, mark the shape of the fuselage on the top & bottom of the horizontal stabilizer. Using a water soluble non-permanent felt-tip pen as shown here.

Step 7.2 Now remove the horizontal stabilizer. Using a sharp knife & a ruler CAREFULLY cut 1/8" (3 mm) inside the marked lines & remove the covering on the top & bottom of the horizontal stabilizer as illustrated. Make sure you **only cut the film & not the wood**, otherwise the horizontal stabilizer will be severely weakened & fail. **USA CA TO FILL AND REPAIR ANY CUT MARKS IN THE WOOD.**



7A- Mark the top of the horizontal stabilizer...



7B- ...and the bottom



7C- Marked lines on horizontal stab



7D- Cutting inside the lines. **Do NOT cut the wood**



7E- Remove the covering from top surface



7F- Exactly the same underneath



7G- Clean off the pen lines

Step 7.3 Now apply sufficient epoxy to the top and bottom of the horizontal stabilizer and horizontal slot. Use 30 minute epoxy to ensure a strong bond and give yourself plenty of working time. See 7H & 7I

Step 7.4 Insert the horizontal stabilizer in its slot in the fuselage and re-check the alignment as in Stage 6. See 7J & 6B

Step 7.5 Excess epoxy should be cleaned off with a rag or tissue before it cures. See 7K

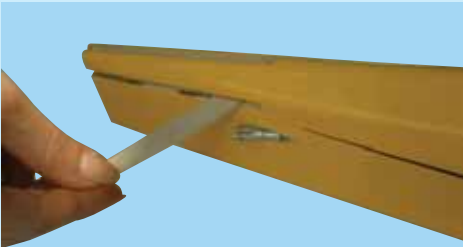

7H- Apply plenty of 30 minute epoxy into the horizontal stabilizer slot



7I- Apply plenty of 30 minute epoxy to the horizontal stabilizer



7J- Slide the horizontal stabilizer into place



7K- Wipe off excess 30 minute epoxy

STAGE 8 FITTING THE VERTICAL STABILIZER

Step 8.1 Check the fit of the vertical stabilizer in its slot. Make sure that it is square to the horizontal stabilizer and fuselage. See 8A

Step 8.2 Mark the shape of the fuselage on the left & right sides of the vertical stabilizer using a felt-tip pen. See 8B

Step 8.3 Now remove the vertical stabilizer. Using a sharp knife & ruler CAREFULLY cut just 1/8" (3mm) inside the marked lines (see 8C) and remove the covering on both sides of the fin (see 8D), just as you did with the horizontal stabilizer, making sure you only press hard enough to cut the covering, not the vertical stabilizer. **USA CA TO FILL AND REPAIR ANY CUT MARKS IN THE WOOD.**



8A- Trial fit the vertical stabilizer into the fuselage slot



8B- Mark both sides of the vertical stabilizer



8C- Carefully cut through the covering. Do NOT cut the wood



8D- Remove covering from both sides

Step 8.4 Now apply sufficient epoxy to both sides & the bottom of the vertical stabilizer as illustrated in 8E. Use 30 minute epoxy to ensure a strong bond and give yourself plenty of working time.

Step 8.5 Insert the vertical stabilizer in its slot in the fuselage and re-check the alignment. Excess adhesive should be cleaned off with a rag or tissue before it cures.



8E- Apply plenty of 30 minute epoxy



8F- Slide the stab into place & remove excess epoxy

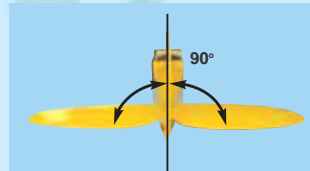

8G- 90 degree angle between the horizontal and vertical stabs.

STAGE 16 CONNECTING THE PUSHRODS TO THE RUDDER AND ELEVATOR SERVOS

Consult illustration 16A & carefully connect the control rods to the servos using the clevises as shown.

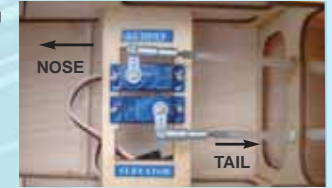

16A- Center the servo control surface and then connect the control rods to the servos using the clevises as shown

STAGE 17 CONNECTING THE PUSHROD TO THE ELEVATOR

Connect the elevator servo to the receiver and turn on your transmitter & then your receiver. Center the transmitter stick and trim. Adjust the servo arm and clevises to center (not up, not down) the elevator as shown in 17A and 17B.



17A- Elevator control horn shown in position



17B- Hold the elevator at neutral (not up, not down). Rotate the clevis to adjust the overall length. Then use the clevis screw to attach the clevis to the control horn. The clevis screw requires a 5/64 in. (2mm) hole. Secure the screw with thread lock

STAGE 18 CONNECTING THE PUSHROD TO THE RUDDER

Connect the rudder servo to the receiver and turn on your transmitter & then your receiver. Center the transmitter stick and trim. Adjust the servo arm and clevises to center (not left, not right) secure the rudder as shown in 18A.



18A- Hold the rudder at neutral (not left, not right). Rotate the clevis to adjust the overall length. Then use the clevis screw to attach the clevis to the control horn. The clevis screw requires a 5/64 in. (2mm) hole. Secure the screw with thread lock

STAGE 19 ADJUST CONTROL SURFACE THROW LIMITS

Adjust the deflection of the control surfaces to match the specifications on page 12. You can reduce the amount of throw by doing either or both of the following:

- From the servo end, move the clevis to a hole in the servo arm that is closer to the servo output shaft.

- From the control horn end, move the control rod/clevis further out on the horn (away from the control surface). Always confirm that the clevis is firmly attached after making any adjustment.

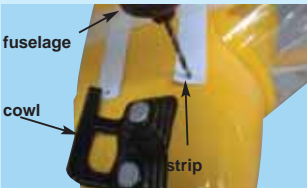

13E- Do not move the cowl. Drill through the dot, the cowl and all four mounting positions



13F- Secure the cowl into place with four 2x10 [mm] screws

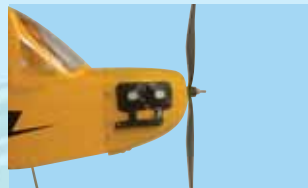

13G- With the **BATTERY & FUSE REMOVED** securely install the propeller

STAGE 14 FITTING THE ELEVATOR AND RUDDER CONTROL HORNS

Lightweight laser cut horns are used on this model (see 14A). Remove covering from the mounting locations. Attach firmly with 30 minute Epoxy as shown in 14B, 14C and 14D.

WICK THIN CA AROUND CLEVIS HOLES AFTER INSTALLING HORNS.



14A- Typical control horn assembly



14B- Typical control horn after installation



14C- Elevator control horn location



14D- Rudder control horn location

STAGE 15 INSTALLING THE SERVOS

Install the rubber servo grommets & brass ferrules supplied with your radio equipment. The two servos that control the elevator and rudder are to be installed in the servo tray mounted in the fuselage. Remove the servo tray from the fuselage, mounting the servos to the servo tray as shown in 15A and 15B. And then install the servo tray back into the fuselage as shown in 15C. Hook up the control rods as shown in 15D.



15A- Servo tray

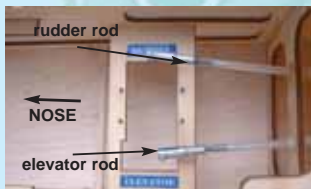

15B- Note the orientation and positions of the elevator and rudder control rods



15C- Note the orientation and positions of the two servos in the servo tray

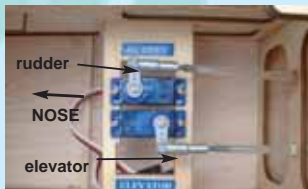

15D- Connect the elevator and rudder control rods to the servo arms

STAGE 9 INSTALLING THE LANDING GEAR

The J3 piper cup has a tail dragger gear configuration using a tail wheel and main landing gear.



STAGE 10 FITTING THE MAIN LANDING GEAR

Identify the main landing gear components shown below

- 2 pre-assembled main landing gear
- Pre-assembled tail wheel
- Three 3x8 [mm] bolts with nuts and washers

NOTE: In some markets this model is supplied with fairings for the main landing gear. If your model was supplied with fairings and you wish to install them please use the fasteners provided and consult the picture in Stage 9.

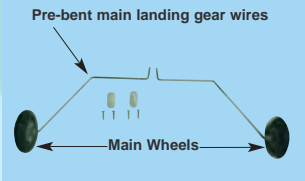

10A- Main landing gear components



10B- Pre-drilled holes for the main landing gear installation



10C- Insert the pre-bent main landing gear into the fuselage



10D- Use two straps and four 10x2mm screws to mount the main landing gear assembly

STAGE 11 INSTALLING THE TAIL WHEEL

Identify the tail wheel components per illustration 11A:
- 1 tail wheel assembly

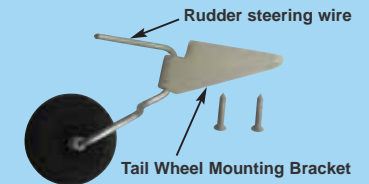

11A- Tail wheel assembly



11B - Insert the rudder steering wire into the steering tube on the bottom of the rudder.



11C - Screw the tail wheel mounting bracket to the fuselage.



11D - Trim off the excess rudder steering wire.

STAGE 12 INSTALLING THE ELECTRIC MOTOR AND ESC

Electric motors vary in size, styles and mounting method. Always refer to the mounting instructions applicable to your motor.

We illustrate the general installation procedure here utilizing the recommended standard VMAX Brushless Motor

#VMM 111B18VM (factory ref # Va 2410-12) and VMAX 15 Amp Speed Control with BEC (#VMC-120B15VC).

If you have purchased a pre-assembled VMAX power module assembly consisting of firewall, motor and speed control you may skip 12A through 12E.

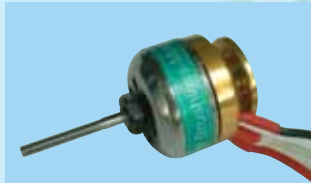

12A- VMAX Brushless Motor #VMM 111B18VM (factory ref # Va 2410-12) recommended



12B- A special pre-drilled firewall is included for mounting the recommended VMAX motor. A blank firewall is also provided for other motor installations



12C- Securely mount the aluminum motor backing plate to the firewall using 4, bolt & washer sets provided. Tighten the bolts securely and apply thread locker such as Pacer Z-42 (Blue)



12D- Route the motor wire to the back of the firewall as shown

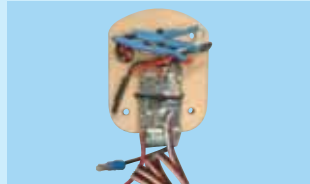

12E- Mount the Speed Control to the back of the firewall so that the metal heat sink faces the ventilation hole (forward). Secure in place with a tie-wrap

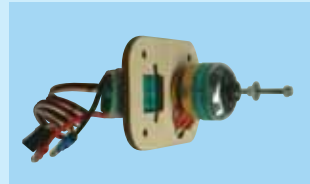

12F- Assembled Power Module complete with firewall, motor & speed control



12G- Fuselage front former

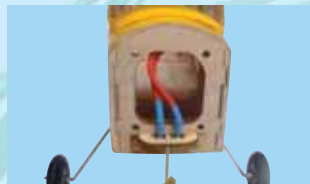

12H- Mount the pre-assembled fuse holder/switch to the fuselage front former

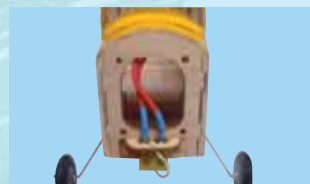

12I- Test fit a 20 Amp automotive spade fuse into the fuse holder/switch and then **REMOVE THE FUSE**



12J- Install four 3x50 [mm] bolt sets (supplied). Bolt-washer-former-washer-nut (front). Tighten the nuts securely & apply thread locker



12K- Thread four 3 mm nuts onto the bolts as shown. The nuts should be all be evenly spaced at .875 in. (22 mm) from the firewall



12L- Place four 3 mm washers on the bolts & then position the assembled power module. Secure in place with four more 3 mm washers & nuts. Tighten snugly

Fuse holder/Switch. The fuse is to be inserted only when flying or testing. **ALWAYS REMOVE THE FUSE WHEN NOT FLYING OR TESTING**

WARNING
WRONG CONNECTIONS
WILL DESTROY COMPONENTS.

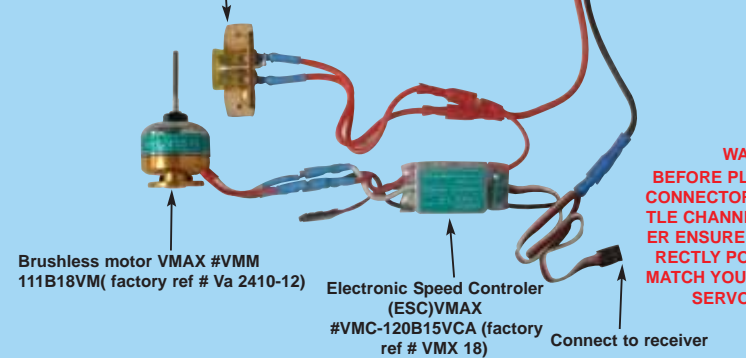

WARNING
BEFORE PLUGGING THIS
CONNECTOR INTO THROTTLE
CHANNEL OF RECEIVER
ENSURE PLUG IS CORRECTLY
POSITIONED TO MATCH YOUR
RECEIVER & SERVO WIRING.

12M- Typical wiring for electric power system.

STAGE 13 INSTALL THE COWL AND PROPELLER

Install and align the cowl using the four cowl mounting screws provided. The screws pass through the sides of the cowl and into the tabs on the front of the fuselage.

Step 13.1 Cut card stock strips about 1/2 x 5" (12x120 mm). Use low tack masking tape to position the strips as shown in 13B. & 13C

Note that the tape is applied towards the rear of the strips and that the front of the strips overlap the cowl mounting tabs at the front of the fuselage.

Step 13.4 Mark the mounting hole locations with a DOT per 13C. Without moving the cowl, carefully hold each strip flat against the cowl and working around the cowl one strip at a time, drill a 5/64 in. (2 mm) hole through the dot, the cowl and the mounting tab. See 13E.

Step 13.5 Hold the cowl in place using four 2x10 [mm] screws. Carefully remove the strips and all masking tape.

Step 13.6 With the **BATTERY & FUSE REMOVED** securely install the propeller. Double check your work and ensure that the propeller is securely attached and will not come off.

Step 13.2 Mark each strip with a dot in the center of each cowl mounting tab as shown in 13C.

Step 13.3 Slide the cowl into place to completely cover the mounting tabs on the fuselage & such that the strips are outboard of the cowl as shown in 13D. Align the cowl so that the motor shaft is centered.

Secure the cowl in position with low tack masking tape.



13A- Pre-painted cowl supplied



13B- Card stock strips overlying the cowl mounting tabs on the left and right side of the fuselage

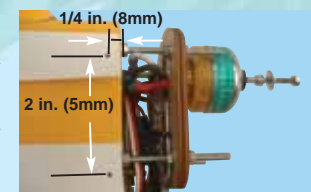

13C- Mark the strip with a dot at the center of each cowl mounting location



13D- Position the cowl over the mounting tabs. Note the strips are outboard. Align & center with respect to the motor shaft